

Noisy copies ρ

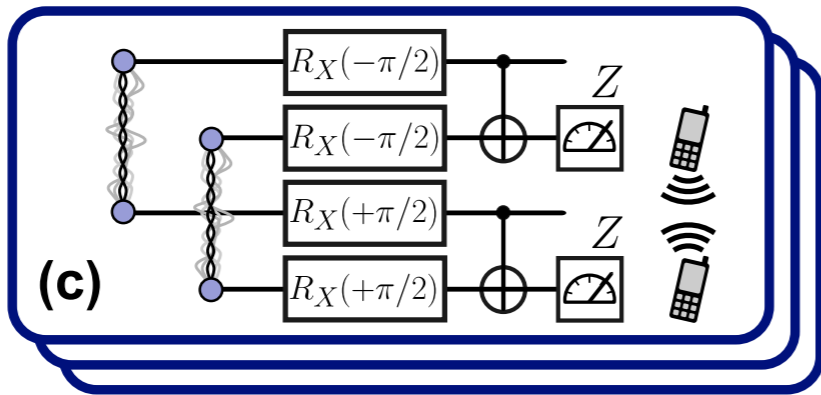

Measurement statistics $\{\hat{p}^{(i)}\}$

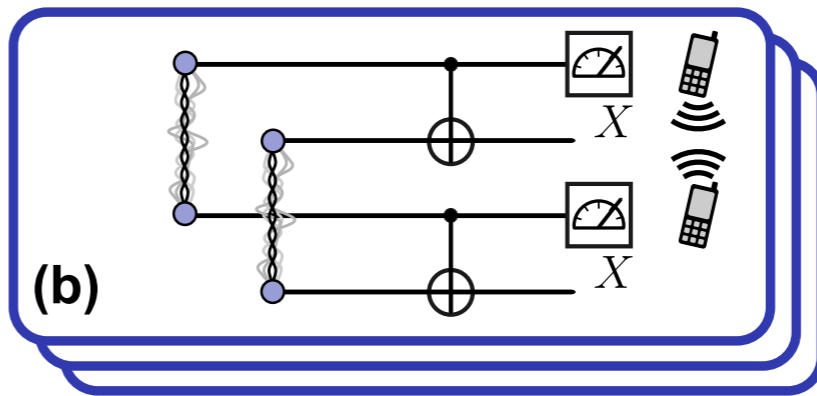
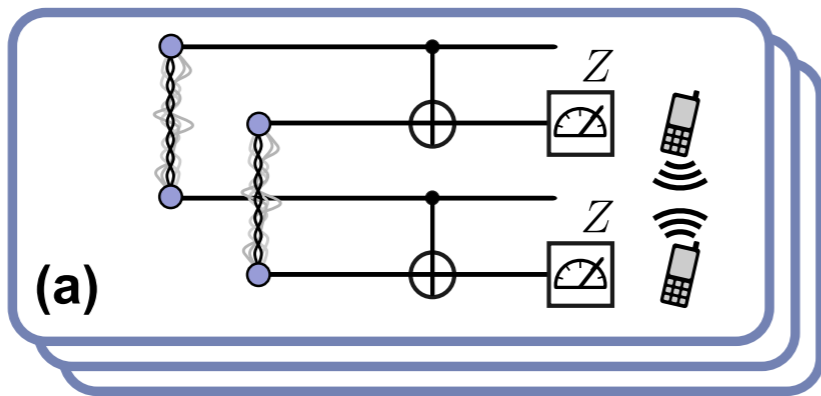
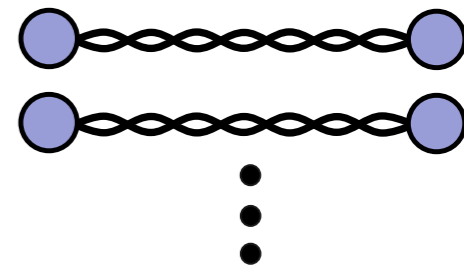

Distilled copies

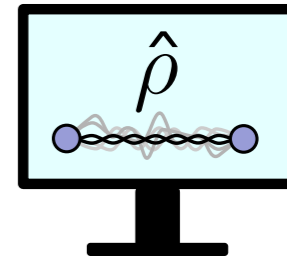

State estimation